

NOTE: All Assembly Order Numbers are for bead plate parts unless noted otherwise.

	Description	Assembly Order No.
Style 22	Blind nuts, 1/4 BSP	W01-M58-6381
	Blind nuts, 1/4 BSP, bumper	W01-M58-6382
Two Ply Bellows	Blind nuts, 3/4 BSP	W01-M58-6200
	Blind nuts, 3/4 BSP, bumper	W01-M58-6201
	Countersunk steel bead rings, 40 mm bolts, nuts, washers	W01-M58-7524
	Rubber bellows only	W01-358-0226
Assembly weight (bead plate version, no bumper)		5.8 kg.
Force to collapse to minimum height (@ 0 BAR)		88.9 N.

Style 210	Blind nuts, 1/4 BSP	W01-M58-6212
	Blind nuts, 3/4 BSP	W01-M58-6210
High Strength Construction	Countersunk steel bead rings, bolts, nuts, washers	W01-M58-6976
	Rubber bellows only	W01-358-7928

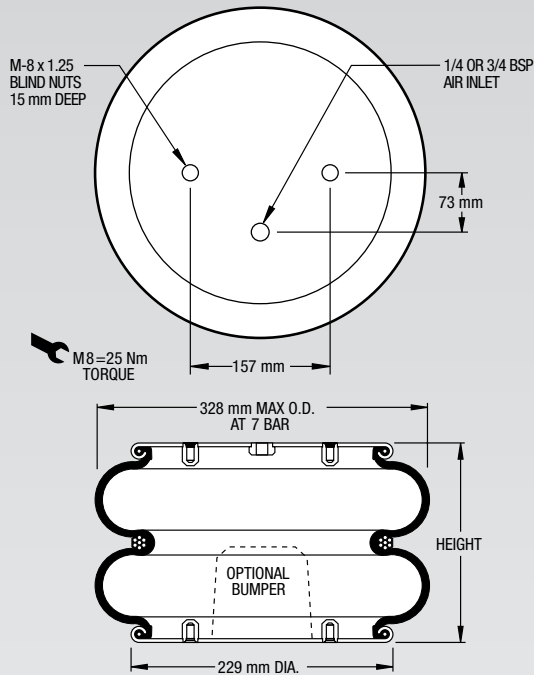

NOTE: A bead plate part is shown. This part is also available with bead rings. See pages 8-10 for explanation.

Dynamic Characteristics at 240 mm Design Height (Required for Airmount isolator design only)			
Gauge Pressure (BAR)	Load (kN)	Spring Rate (kN/m)	Natural Frequency Hz
3	9.68	137	1.88
4	13.12	175	1.82
5	16.56	215	1.80
6	20.35	255	1.77
7	23.81	294	1.75

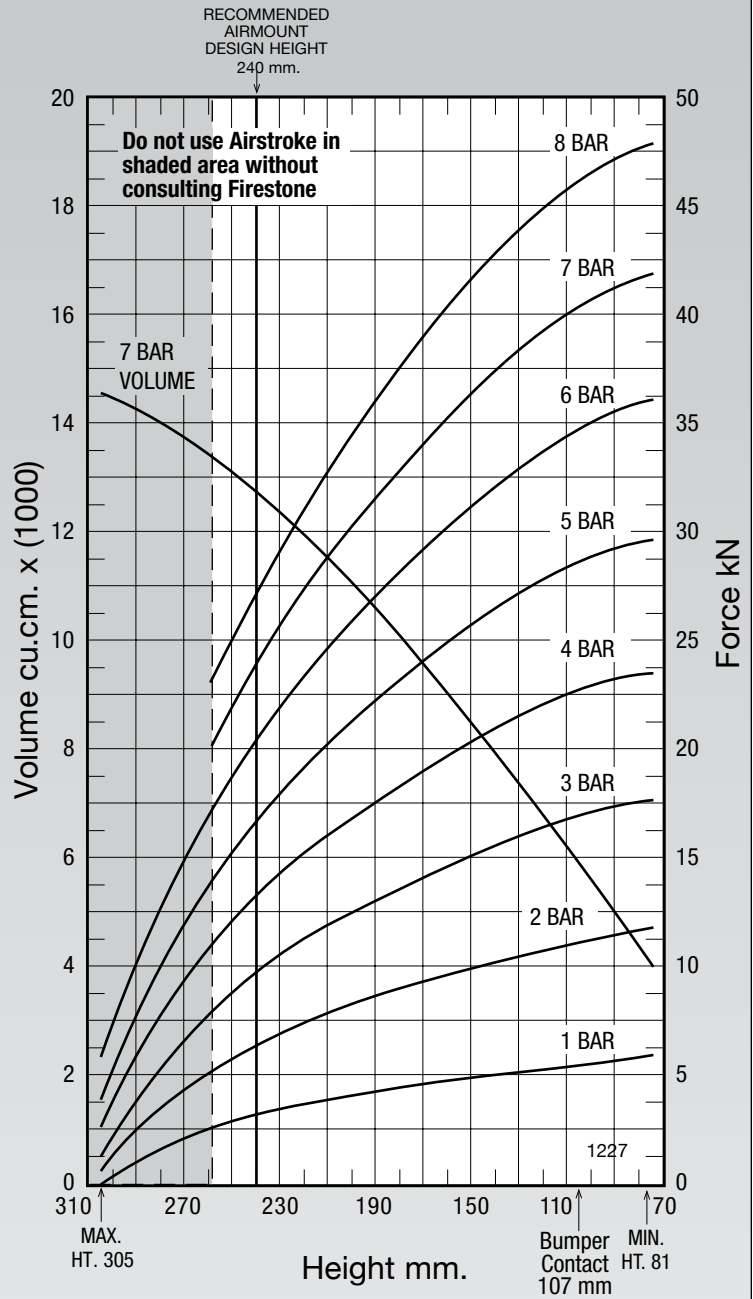

See page 12 for instructions on how to use chart.

Force Table (Use for Airstroke™ actuator design)							
Assembly Height (mm)	Volume @ 7 BAR (cu cm)	EFF Area @ 7 BAR (cm sq)	kN Force				
			@ 3 BAR	@ 4 BAR	@ 5 BAR	@ 6 BAR	@ 7 BAR
240	12776	340	9.68	13.12	16.56	20.35	23.81
220	12002	389	11.22	15.11	19.05	23.31	27.21
200	11107	431	12.49	16.79	21.19	25.89	30.16
180	10127	469	13.60	18.28	23.10	28.21	32.81
160	9072	504	14.61	19.64	24.85	30.32	35.24
140	7952	535	15.56	20.90	26.42	32.23	37.44
120	6815	562	16.42	22.03	27.80	33.85	39.32
100	5637	583	17.15	22.94	28.90	35.12	40.78