



Firestone

268

NOTE: All Assembly Order Numbers are for bead plate parts unless noted otherwise.

	Description	Assembly Order No.
Style 25	Blind nuts, 1/4 BSP	W01-M58-6160
Two Ply Bellows	Socket head aluminum bead rings (bolts, nuts, washers not included—use M6 cap screws)	W01-358-0030
	Rubber bellows only (no girdle hoop)	W01-358-0025
Assembly weight		1.72 kg.
Force to collapse to minimum height (@ 0 BAR)		85 N.

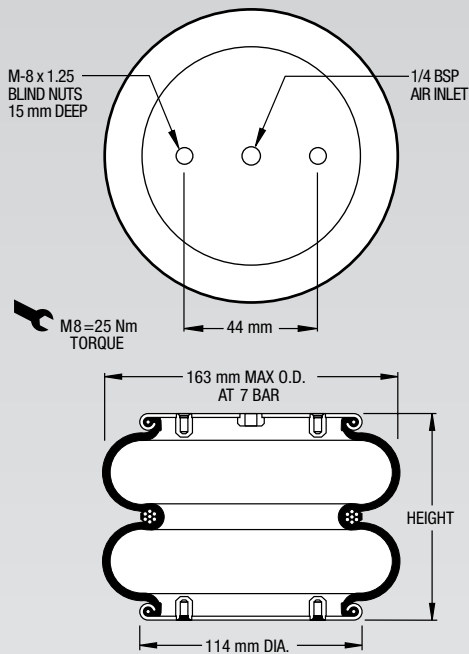

NOTE: A bead plate part is shown. This part is also available with bead rings. Bolts are not included. See pages 8-10 for explanation.

Dynamic Characteristics at 140 mm Design Height (Required for Airmount isolator design only)			
Gauge Pressure (BAR)	Load (kN)	Spring Rate (kN/m)	Natural Frequency Hz
3	2.03	62	2.75
4	2.81	80	2.67
5	3.63	98	2.60
6	4.50	117	2.55
7	5.30	135	2.52

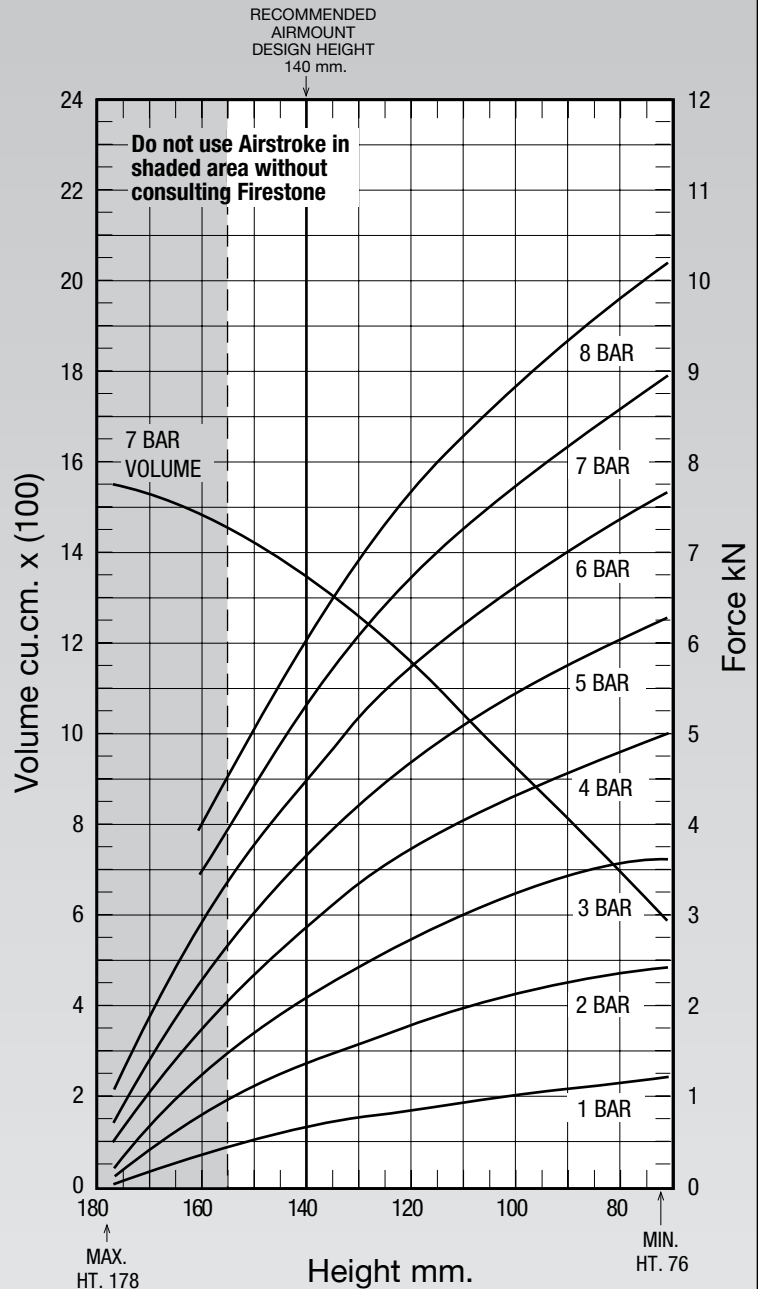

See page 12 for instructions on how to use chart.

Force Table (Use for Airstroke™ actuator design)							
Assembly Height (mm)	Volume @ 7 BAR (cu cm)	EFF Area @ 7 BAR (cm sq)	kN Force				
			@ 3 BAR	@ 4 BAR	@ 5 BAR	@ 6 BAR	@ 7 BAR
150	1421	62	1.64	2.29	2.92	3.66	4.32
140	1344	74	2.03	2.81	3.63	4.50	5.30
130	1253	85	2.39	3.27	4.13	5.09	5.96
120	1159	95	2.69	3.66	4.61	5.66	6.62
110	1049	103	2.97	4.00	5.04	6.16	7.18
100	939	109	3.21	4.27	5.38	6.57	7.65
90	817	116	3.41	4.52	5.69	6.95	8.10
80	698	122	3.55	4.76	5.98	7.31	8.52