

FS 530-11

CONTI® Single Convolution Air Spring

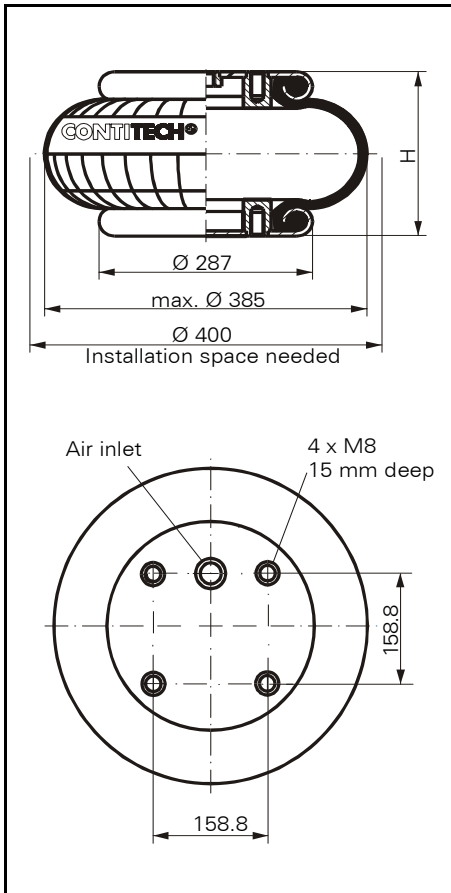

FS 530-11

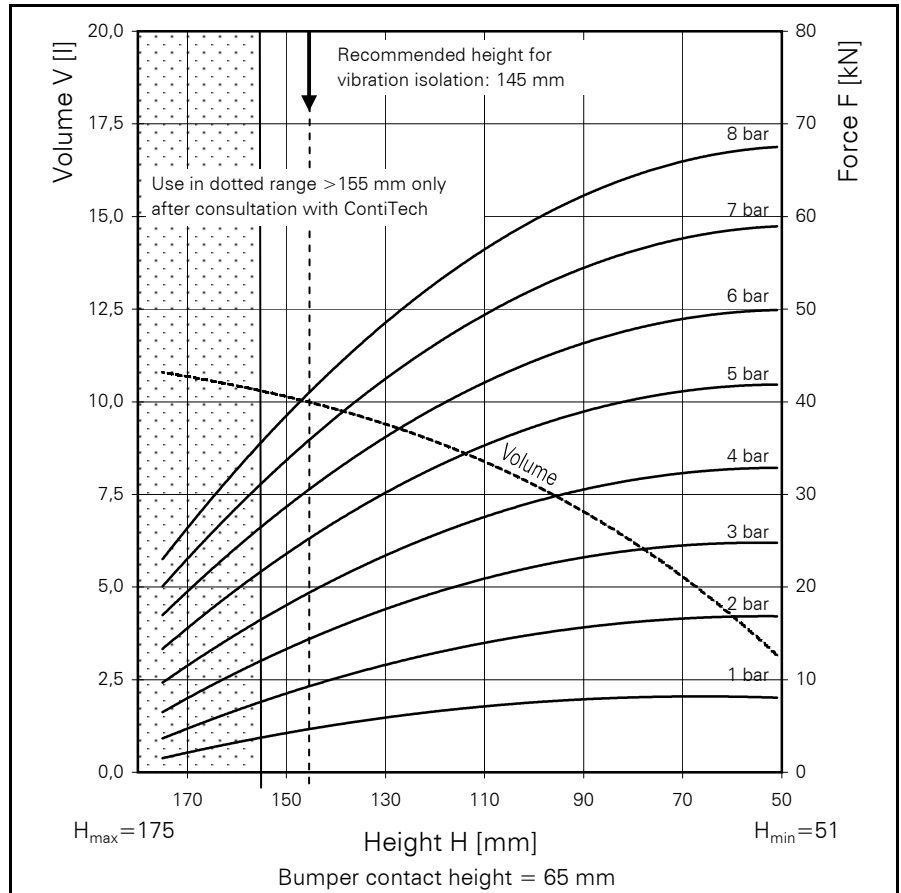

Force-height diagram

Purchase order data

Type	Order No.
Rubber bellows only	60381
With clamped plates G 1 air inlet 79.4 mm excentrical	2681 075 000
With clamped plates G 1/4 air inlet 79.4 mm excentrical	61359
With clamped plates G 1/4 air inlet 79.4 mm excentrical with bumper	60970

Additional types on request



Service instructions
 M8 = 25 Nm
 G 1 = 50 Nm
 G 1/4 = 25 Nm

Technical data

Min. pressure	0 bar
Return force to min. height	≤ 300 N
Overall weight with clamped plates	5.9 kg

Vibration isolation - dynamic characteristic values

Design height H: recommended 145mm, minimum 110mm

Pressure p [bar]	3	4	5	6	7	8	Vol. V [l]
Force (Load) [kN]	15.2	20.1	26.5	31.6	36.9	42.2	10.1
Spring rate [N/cm]	3970	5000	6080	7100	8130	9150	
Natural frequency [Hz]	2.6	2.5	2.4	2.4	2.3	2.3	

Pneumatic application - static characteristic values

Force F [kN]

Pressure p [bar]	3	4	5	6	7	8	Vol.[l]	
Height H [mm]	150	14.3	19.0	25.0	30.0	35.0	40.0	10.1
	130	17.8	23.7	30.5	36.3	42.7	49.1	9.4
	110	20.7	27.4	34.8	41.7	49.0	56.0	8.4
	90	22.8	30.0	38.1	46.0	53.9	61.6	7.1
	70	24.3	32.0	41.2	48.8	57.4	65.5	5.3