

FD 120-20

CONTI® Double Convolution Air Spring

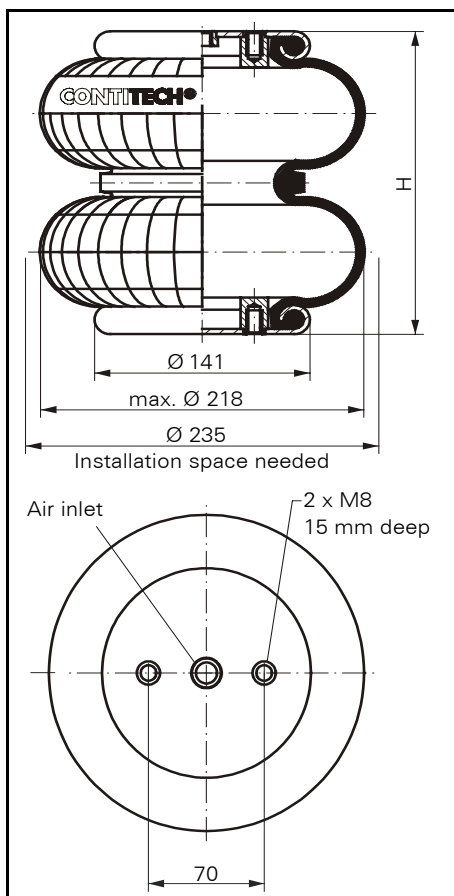

FD 120-20

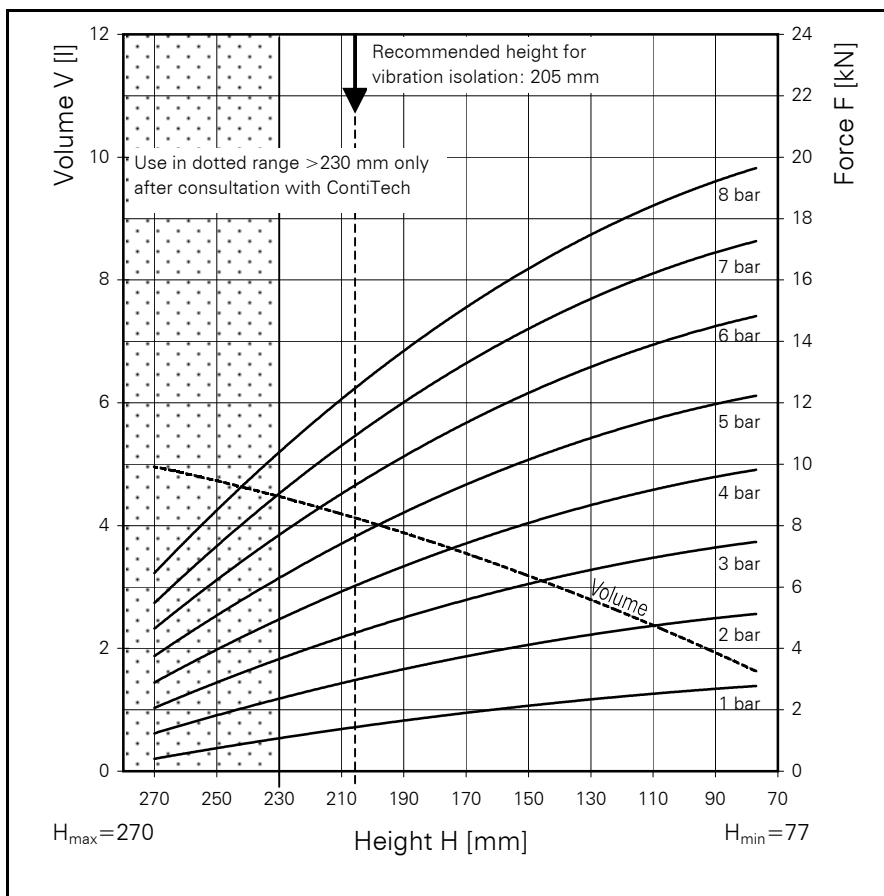

Force-height diagram

Purchase order data

Type	Order No.
Rubber bellows only	on request
With clamped plates G 3/4 air inlet	62055

Additional types on request

Technical data

Min. pressure	0 bar
Return force to min. height	≤ 200 N
Overall weight with clamped plates	2.3 kg

Vibration isolation - dynamic characteristic values

Design height H: recommended 205mm, minimum 190mm

Pressure p [bar]	3	4	5	6	7	8	Vol V [l]
Force (Load) [kN]	4.6	6.2	7.8	9.4	11.1	12.7	
Spring rate [N/cm]	650	840	1030	1200	1390	1541	
Natural frequency [Hz]	1.9	1.8	1.8	1.8	1.8	1.7	

Pneumatic application - static characteristic values

Force F [kN]

Pressure p [bar]	3	4	5	6	7	8	Vol.[l]	
Height H [mm]	200	4.7	6.2	7.9	9.6	11.2		12.9
	160	5.8	7.8	9.8	11.9	13.9		15.8
	120	6.8	9.0	11.3	13.7	16.0		18.0
	80	7.3	9.7	12.1	14.7	17.1		19.5



Service instructions
M 8 = 25 Nm
G 1/4 = 25 Nm