

FD 200-19

CONTI® Double Convolution Air Spring

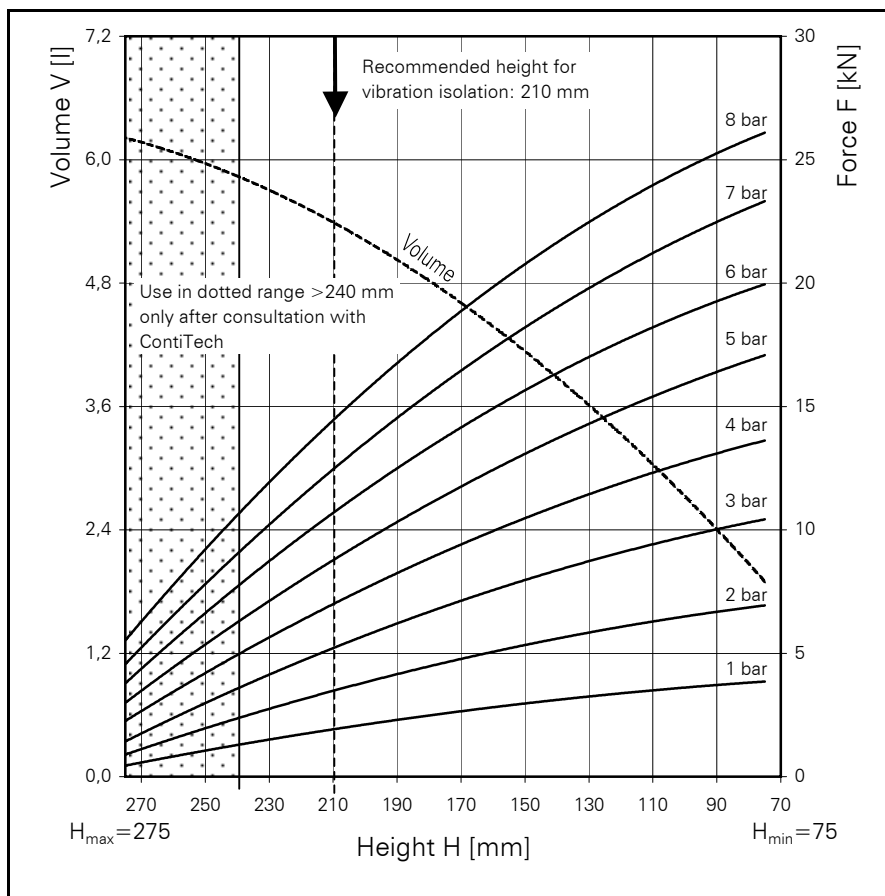
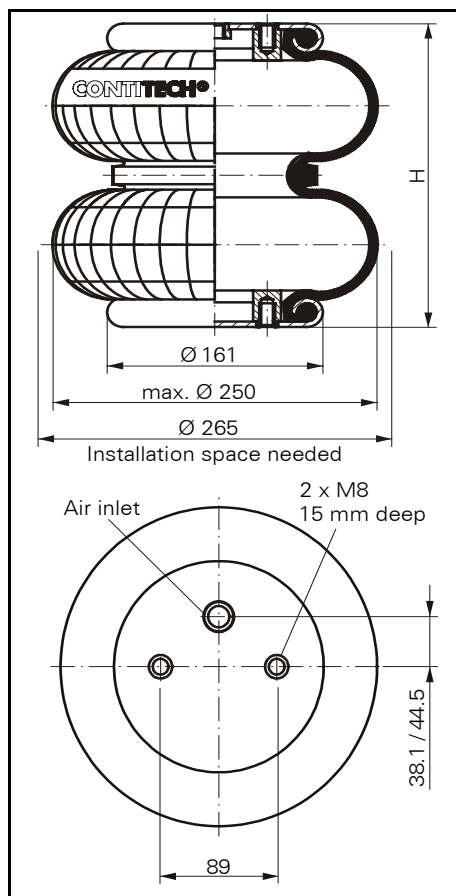

FD 200-19

Force-height diagram

Purchase order data

Type	Order No.
Rubber bellows only	2682 089 845
With clamped plates G 3/4 air inlet 38.1 mm excentrical	2682 045 000
With clamped plates G 1/4 air inlet 44.5 mm excentrical	60336

Additional types on request

Technical data

Min. pressure	0 bar
Return force to min. height	≤ 200 N
Overall weight with clamped plates	3.0 kg

Vibration isolation - dynamic characteristic values

Design height H: recommended 210mm, minimum 195mm

Pressure p [bar]	3	4	5	6	7	8	Vol. V [l]
Force (Load) [kN]	5.2	7.1	9.0	10.7	12.4	14.5	5.2
Spring rate [N/cm]	795	1030	1265	1500	1735	1970	
Natural frequency [Hz]	2.0	1.9	1.9	1.9	1.9	1.9	

Pneumatic application - static characteristic values

Force F [kN]

Pressure p [bar]	3	4	5	6	7	8	Vol.[l]	
Height H [mm]	230	4.1	5.6	7.2	8.8	10.1	12.0	5.8
	200	5.7	7.7	9.6	11.6	13.5	15.6	5.3
	170	7.2	9.4	11.7	14.2	16.5	18.9	4.6
	140	8.4	10.9	13.7	16.4	19.0	21.5	3.9
	110	9.4	12.4	15.4	18.3	21.3	24.1	3.0
	80	10.3	13.4	16.9	19.7	23.0	25.8	2.1



Service instructions
 M8 = 25 Nm
 G 1/4 = 25 Nm
 G 3/4 = 50 Nm