

FD 70-13

CONTI® Double Convolution Air Spring

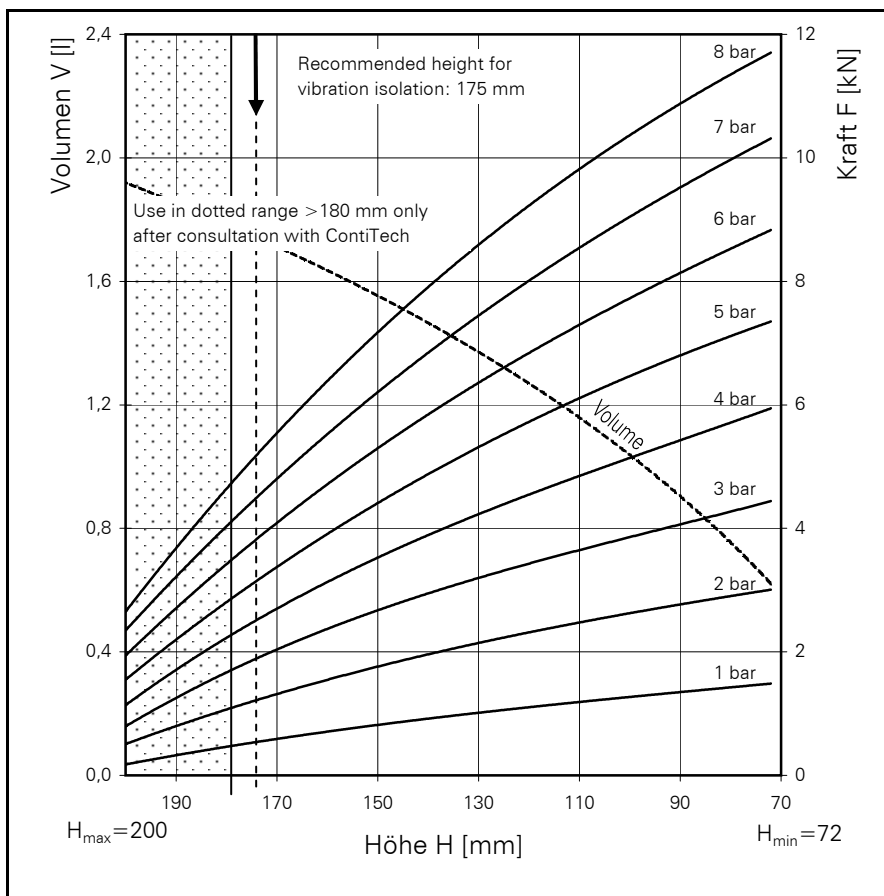
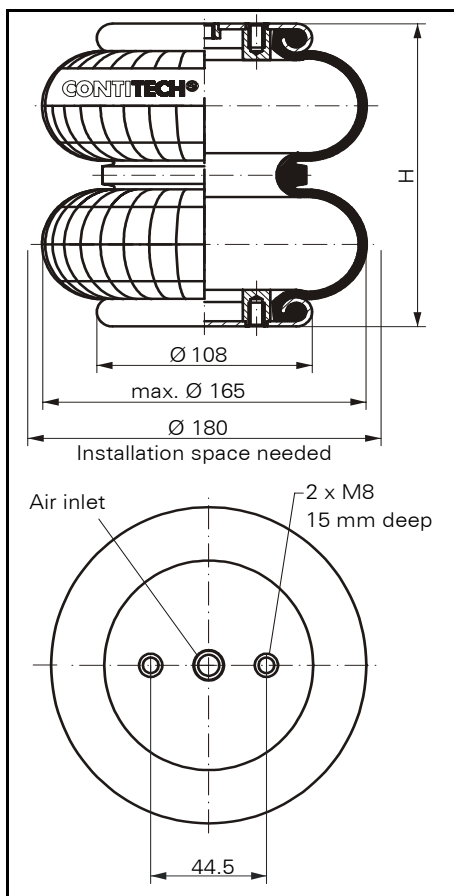

FD 70-13

Force-height diagram

Purchase order data

Type	Order No.
Rubber bellows only	60513
With clamped plates	2682 015 000
G 1/4 air inlet	

Additional types on request

Technical data

Min. pressure	0 bar
Return force to min. height	≤ 200 N
Overall weight with clamped plates	1.5 kg

Vibration isolation - dynamic characteristic values

Design height H: recommended 175mm, minimum 160mm

Pressure p [bar]	3	4	5	6	7	8	Vol.[l]
Force (Load) [kN]	1.9	2.5	3.2	3.8	4.5	5.2	1.7
Spring rate [N/cm]	460	595	730	860	995	1.125	
Natural frequency [Hz]	2.5	2.5	2.4	2.4	2.4	2.4	

Pneumatic application - static characteristic values

Force F [kN]

Pressure p [bar]	3	4	5	6	7	8	Vol.[l]
Height H [mm]	180	160	140	120	100	80	
	1.6	2.4	2.9	3.4	3.9	4.3	1.8
	2.3	3.2	3.9	4.5	5.2	5.7	1.6
	2.9	3.9	4.8	5.7	6.5	7.1	1.5
	3.4	4.5	5.7	6.8	7.8	8.5	1.3
	3.9	5.2	6.5	7.8	9.1	10.0	1.1
	4.3	5.7	7.1	8.5	10.0	11.4	0.7



Service instructions
 M8 = 25 Nm
 G 1/4 = 25 Nm